

6 5 4 3 2 1

REVISION HISTORY				
ZONE	REV	DESCRIPTION	DATE	APPROVED
	A		3/27/2020	jj.johnson
	B		5/19/2021	david.kempf
C6	C	Dim. was 4.625	6/18/2021	MEM

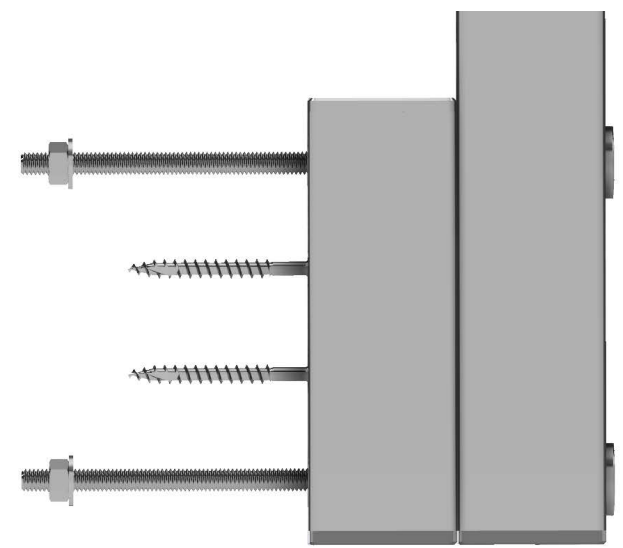
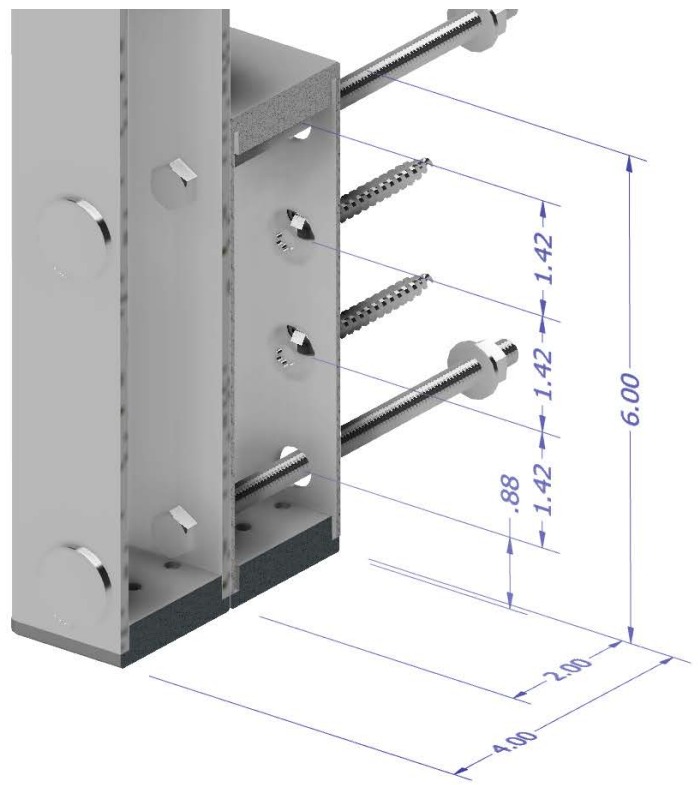

DETAIL B
SCALE 1 : 1

TOLERANCES
 .X = ± .03125 SHEET METAL PARTS
 .XX = ± .010 X = ± 0.5°
 .XXX = ± .003 UNLESS OTHERWISE NOTED

SPECIAL INSPECTION NOTES:

MATERIAL: Stainless Steel (304 or 2205)

MANUFACTURED PARTS
 MANUFACTURING PROCESS:
 RAW MATERIAL COST PER PIECE: \$
 CYCLE TIME PER PIECE (SECONDS):
 FINAL COST PER PIECE: \$

PURCHASED PARTS
 VENDOR:
 VENDOR COST PER PIECE: \$
 VENDOR STOCK NUMBER:
 LINK:

ENG APPROVED BY: JJJ
 ENG APPROVED DATE: 3/27/2020
 MFG APPROVED BY: JJJ
 MFG APPROVED DATE: 3/27/2020



PART NAME: Bump Out Plate
 PART NUMBER:
 DESIGN STATUS: Released
 FILE NAME: 315684_SIDE MOUNT PLATE AL.ipt
 PROJECT: Post Hardware
 DESIGNER: JJJ
 ENGINEER: JJJ
 RECENT REVIEW DATE: 3/27/2020

6 5 4 3 2 1